

Error-free, 12-user, 10 Gbit/s/user O-CDMA network testbed without FEC

R.P. Scott, W. Cong, C. Yang, V.J. Hernandez, N.K. Fontaine, J.P. Heritage, B.H. Kolner and S.J.B. Yoo

Error-free operation of a 12 × 10 Gbit/s synchronous, time-slotted spectral phase-encoded time-spreading optical code division multiple access (O-CDMA) network testbed without using forward-error-correction (FEC) is demonstrated. A nonlinear optical loop mirror time gate and nonlinear thresholding minimise multiuser interference.

Introduction: Lately, there has been a significant amount of interest in optical code division multiple access (O-CDMA) networks [1]. Many different types of O-CDMA networks have been proposed and studied, including those based on spectral phase encoding [2, 3], 2D or wavelength-time encoding [4], and incoherent sources [5]. Recently, an error-free 12-user, 10 Gbit/s/user O-CDMA network was demonstrated [6]. However, this network required the use of forward-error-correction (FEC) to achieve error-free operation, bit error rate (BER) < 10⁻⁹. Without FEC, it achieved a BER of ~10⁻⁵ for 12 users.

In this Letter we present a 10 Gbit/s/user spectral phase-encoded time-spreading (SPECTS) O-CDMA network testbed that operates error-free for up to 12 users without relying on FEC. Several key elements were needed to achieve this unprecedented result. First, operating as a synchronous network allowed for the use of 64-chip Walsh codes which can produce an energy minimum at the coded pulse centre, thus significantly reducing the multiuser interference (MUI). Also, in a synchronous network, time-slotting can be used to increase spectral efficiency and permit code sharing. Secondly, the spectral code width is 18.3 nm, an increase of 83% over our earlier work [3, 7]. Encoder/decoder losses were reduced to < 4 dB, the 20 nm passband has a flatness of better than 1 dB and a resolution of ~0.1 nm. Lastly, the O-CDMA receiver utilises a combination of a narrow time gate and nonlinear thresholder based on highly nonlinear fibre (HNLF) to differentiate between the correctly and incorrectly decoded users and effectively suppress MUI. Although previous work [3, 7] describes some of these elements, here we describe a network testbed that is fully 10 Gbit/s/user and able to run truly error-free for many more users.

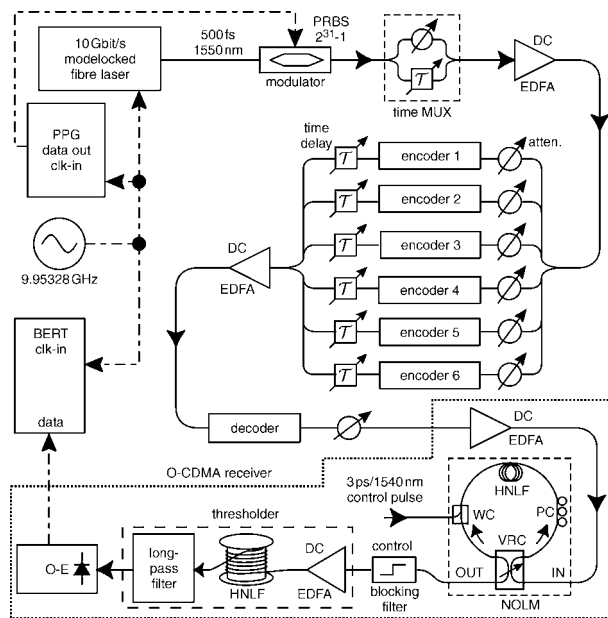

Fig. 1 Experimental setup for 12-user SPECTS O-CDMA network testbed PPG: pseudorandom pulse generator; VRC: variable ratio coupler; WC: wavelength coupler; PC: polarisation controller

Testbed description: The synchronous SPECTS O-CDMA network testbed is shown in Fig. 1. The testbed consists of four major sections: time-slotted signal generator and coding, O-CDMA receiver, control pulse generator, and BER tester (BERT). Generation of the user signals starts with a 10 Gbit/s (OC-192) modelocked fibre laser

(includes a dispersion-decreasing fibre (DDF) pulse compressor, not shown) and it generates ~400 fs pulses centred at 1550 nm. This pulse stream is on-off key (OOK) modulated with a 2³¹ - 1 pseudo-random bit sequence (PRBS) before passing through a time multiplexer (MUX). The time MUX splits the data stream, differentially delays one path with respect to the other, and then recombines them to form a 2 × 10 Gbit/s time-slotted data stream, where each time slot is 50 ps wide. After amplification by a dispersion-compensated, erbium-doped fibre amplifier (DC-EDFA), a one-to-six splitter provides six separate time-slotted data streams that are each encoded with a unique 64-chip Walsh code. Encoders 1-6 use codes (as numbered by MATLAB) 5, 40, 34, 54, 6, and 16, respectively. Each data stream additionally contains time delays that slot align the users and variable attenuators to equalise the users' power. A six-to-one combiner brings together all 12 users and another DC-EDFA compensates for losses. A decoder applies the conjugate of the code used by encoder 1 to all of the users, correctly decoding one pair of users (one of which is the 'intended user') while incorrectly decoding the others (interferers). The encoders are based on a compact, multichannel zero-dispersion pulse shaper and 2D liquid-crystal spatial light phase modulator similar to our previous work [3].

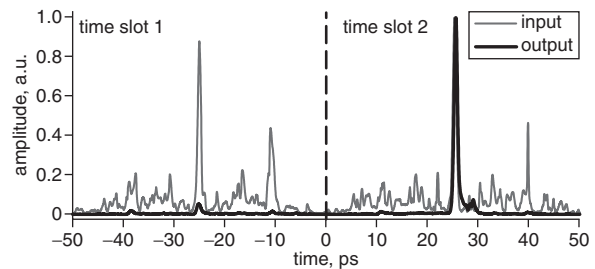

Fig. 2 Time domain cross-correlation of NOLM input and output 400 fs reference pulse width

In the O-CDMA receiver, a nonlinear optical loop mirror (NOLM) time gate is used to select the intended user's time slot (i.e. time demultiplexing). Since the NOLM provides a ~3 ps gate with more than a 15 dB contrast ratio, much of the interfering user's energy is blocked (see Fig. 2). The time gate alone provides error-free operation for up to eight users and a nonlinear thresholder is used to suppress the remaining MUI. In the thresholder HNLF, the high peak power of the intended user's signal generates additional spectra, while the lower peak power of interferers' signals results in little spectral change. Fig. 3 shows the contrast between the spectrum generated by the intended user with all of the interferers, and the spectrum from 10 interferers only. Synchronisation of the time gate is maintained by a 3 ps control pulse at 1540 nm which is derived from a sample of the initial compressed modelocked laser output. A detailed description of the O-CDMA receiver operation is presented in [3]. BER data are taken with respect to the power at the input to the O-CDMA receiver. Although the BERT data clock is directly supplied by the synthesiser, it could also be provided by an optical-electrical (O-E) converter with clock recovery capability.

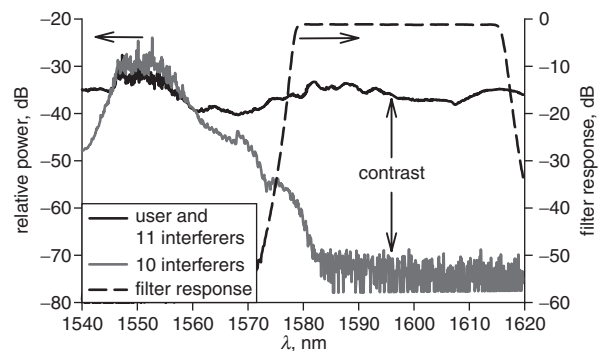

Fig. 3 Nonlinear thresholder HNLF output spectra for 'intended user + interferers' and '10 interferers only' (filter response also shown)

Results and discussion: The performance of the SPECTS O-CDMA network testbed for two to 12 users is shown in Fig. 4. Back-to-back data are taken without the encoders or decoder and successive curves

are taken by sequentially unblocking encoders 1–6. To easily show the impact of adding multiple users, the BER data has been plotted against the received power *per user* at the input to the O-CDMA receiver. The arrow at the end of each curve indicates the minimum power required to achieve error-free operation while collecting more than 10^{12} bits ($\text{BER} < 3 \times 10^{-12}$). Fig. 4 shows that impact of MUI on the BER is minimal for two to 10 users. However, the 12-user curve has nearly a 1.5 dB power penalty ($\text{BER} = 10^{-9}$) and a possible error floor owing to optical signal-to-noise ratio (OSNR) degradation and MUI effects.

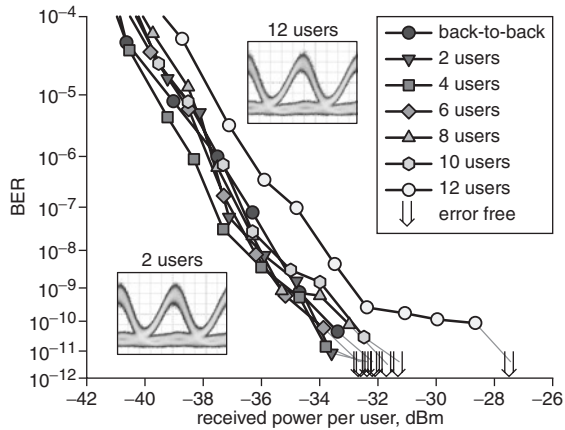

Fig. 4 Performance of 10 Gbit/s/user SPECTS O-CDMA network testbed
Eye diagrams taken at corresponding error-free point

Conclusion: A SPECTS O-CDMA network testbed operating error-free at 10 Gbit/s/user for up to 12 users has been demonstrated. It does not require the use of FEC and since it is a synchronous network, it can accommodate time-slotted operation for improved spectral efficiency and code sharing.

Acknowledgments: This work was supported in part by DARPA and SPAWAR under agreement N66001-02-1-8937 and by the AFOSR through the UC Davis Center for Digital Security.

© IEE 2005

2 November 2005

Electronics Letters online no: 20053862

doi: 10.1049/el:20053862

R.P. Scott, W. Cong, C. Yang, V.J. Hernandez, N.K. Fontaine, J.P. Heritage, B.H. Kolner and S.J.B. Yoo (*Department of Applied Science, and Department of Electrical and Computer Engineering, University of California, Davis, CA 95616, USA*)

E-mail: rpscott@ucdavis.edu

References

- Shah, J.: 'Optical CDMA', *Opt. Photonics News*, 2003, **14**, (4), pp. 42–47
- Jiang, Z., Seo, D., Yang, S., Leaird, D., Roussev, R., Langrock, C., Fejer, M., and Weiner, A.: 'Four-user 10-Gb/s spectrally phase-coded O-CDMA system operating at ~ 30 fJ/bit', *IEEE Photonics Technol. Lett.*, 2005, **17**, (3), pp. 705–707
- Scott, R.P., Cong, W., Hernandez, V.J., Li, K., Kolner, B.H., Heritage, J.P., and Yoo, S.J.B.: 'An eight-user, time-slotted SPECTS O-CDMA testbed: demonstration and simulations', *J. Lightwave Technol.*, 2005, **23**, (10), pp. 3232–3240
- Baby, V., Bres, C.S., Glesk, I., Xu, L., and Prucnal, P.R.: 'Wavelength aware receiver for enhanced 2D OCDMA system performance', *Electron. Lett.*, 2004, **40**, (6), pp. 385–387
- Rochette, M., Ayotte, S., and Rusch, L.A.: 'Analysis of the spectral efficiency of frequency-encoded OCDMA systems with incoherent sources', *J. Lightwave Technol.*, 2005, **23**, (4), pp. 1610–1619
- Wang, X., Wada, N., Cincotti, G., Miyzaki, T., and Kitayama, K.: 'Demonstration of 12-user, 10.71 Gbps truly asynchronous OCDMA using FEC and a pair of multi-port optical-encoder/decoders'. 31st European Conf. on Optical Communication (ECOC 2005) 2005, Paper Th4.5.3
- Cong, W., Scott, R.P., Hernandez, V.J., Li, K., Heritage, J.P., Kolner, B.H., and Yoo, S.J.B.: 'High performance 70 Gbit/s SPECTS optical-CDMA network testbed', *Electron. Lett.*, 2004, **40**, (22), pp. 1439–1440